

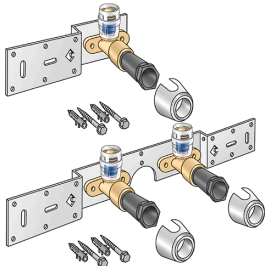

KMP485X KELOX-PROTEC CLIX Anschluss-Set



Symbolgrafik

Produktbeschreibung:

Mit KMP480X Wandscheibe, schallgedämmt, Stopfen, Metallhalterung, Dübel und Befestigungselemente KEINE Gewinderohre und Tempergussfittings eindrehen!



Produkteigenschaften:

ÖVGW	W 1.235	DVGW	DW-8501CM0535
SVGW	1209-6082		

Erweiterte Produkteigenschaften:

Art.-Nr.	Bezeichnung	Gewicht	VPE1	VPE2	Mengeneinheit
730261B02	16x1/2" Einzelanschl.	0,48 KGM	1	15	STK
730262B02	16x1/2" 8-10cm	0,92 KGM	1	15	STK
730266B02	16x1/2" 15cm	0,94 KGM	1	15	STK
730261D02	20x1/2" Einzelanschl.	0,49 KGM	1	15	STK
730262D02	20x1/2" 8-10cm	0,94 KGM	1	15	STK
730266D02	20x1/2" 15cm	0,97 KGM	1	15	STK





KMP485X KELOX-PROTEC CLIX Anschluss-Set

16x1/2"

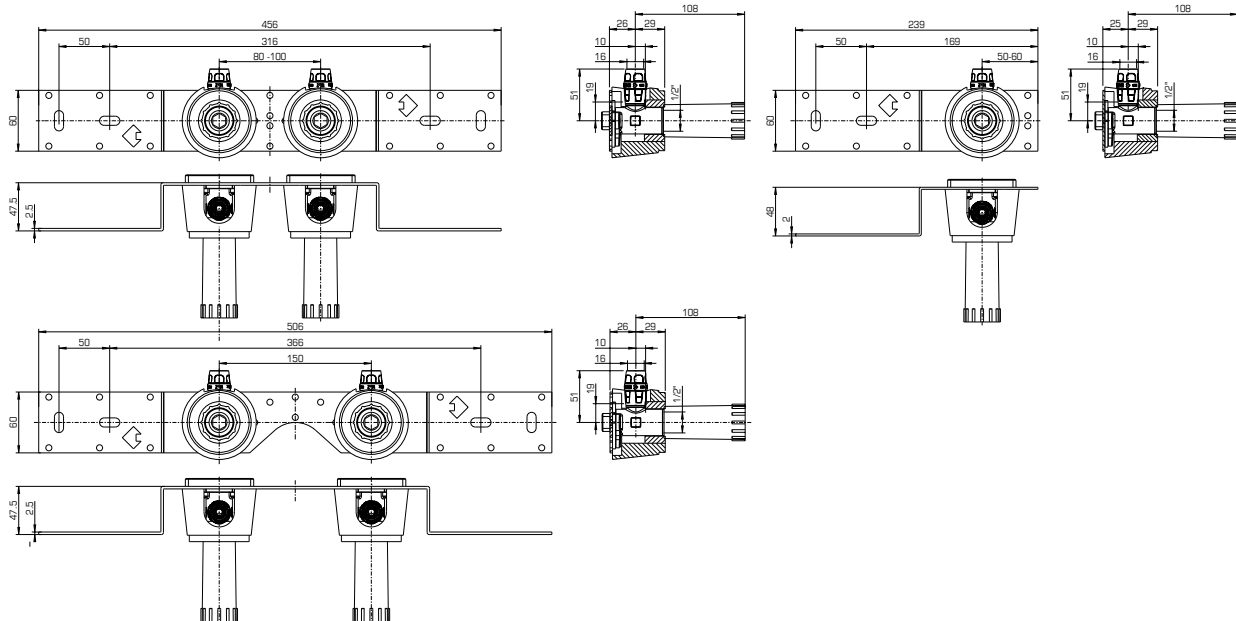

20x1/2"

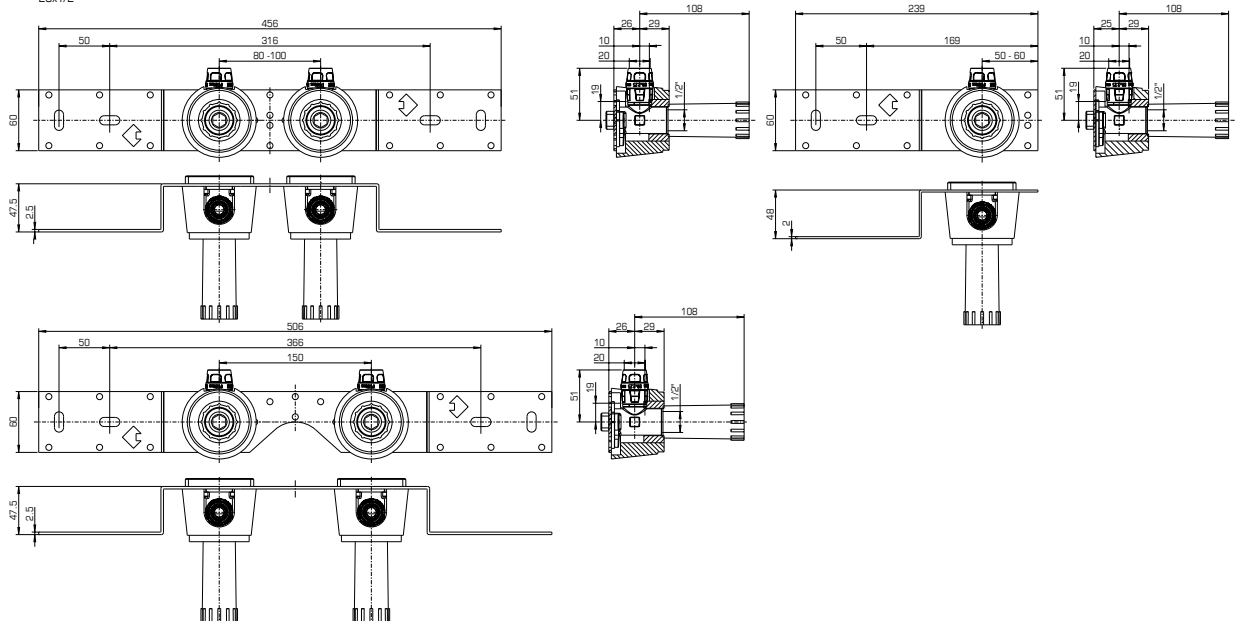

Art.-Nr.	Bezeichnung
730261B02	16x1/2" Einzelanschl.
730262B02	16x1/2" 8-10cm
730266B02	16x1/2" 15cm
730261D02	20x1/2" Einzelanschl.
730262D02	20x1/2" 8-10cm
730266D02	20x1/2" 15cm

