

Product no.: 707611

Dimensions in mm and [inch]

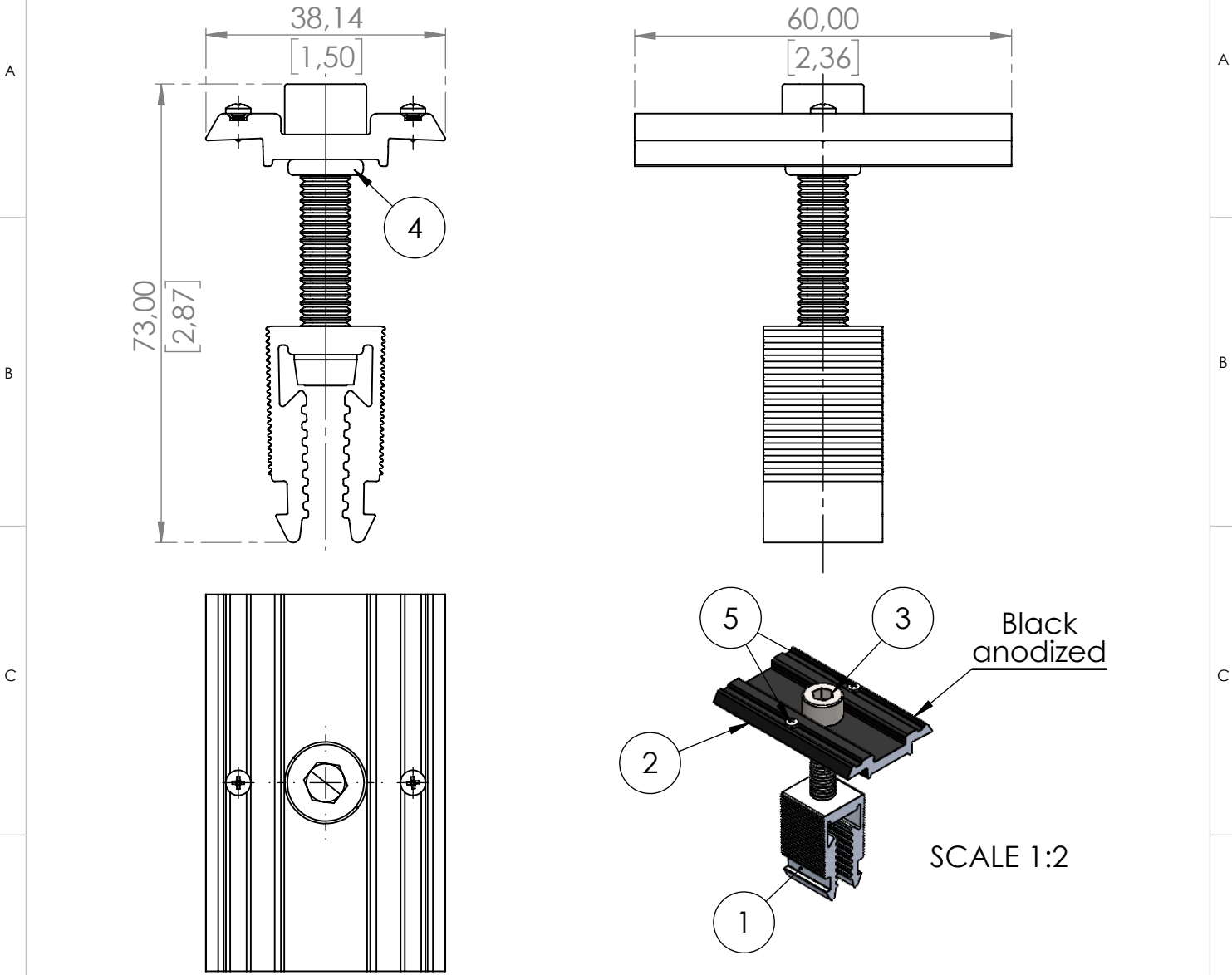

Pos. No.	Pcs	Description	Material
1	1	Clip module clamp	EN AW-6063 T66 (HBW 75-80)
2	1	Middle clamp black anodized	EN AW-6063 T66 (HBW 75-80)
3	1	Allen head screw M8x40 with serration - ISO 4762	A2-70
4	1	O-ring Ø12/Ø7x2,5mm Class B - ISO 3601	EPDM
5	2	Pan head tapping screw - ISO 7049	A2

Standard: EN 1090 EXC1		Tolerances:		DIN ISO 128-30		xxxx Inspection dimensions		Scale: 1:1 1:2		Weight: 0.06 kg	
G								Material:			
F		Norm in Part List adjusted & drawing update		08.06.22 mau		established 10.07.2019 mau		Surface:			
F		New clip and clamp geometry		08.06.20 mru		approved 12.08.2022 fpr		Title: CLMB10			
E		Flow drill added, square nut removed		07.05.20 mru		released 12.08.2022 fpr		Middle clamp 30-46mm black anodized			
D		O-ring Ø7/Ø12 x 2,5mm		18.03.20 nan		AEROCOMPACT® www.aerocompact.com office@erocompact.com		Drawing No.: 707611		Index: F	
C		O-ring Ø7/Ø11, additional hardness		29.02.20 mru							
B		New clip		28.10.19 mru							
A		Current status		10.07.19 mau							
		Modification		Date Name						Page: 1	

Für diese Zeichnung behalten wir uns alle Rechte vor, auch für den Fall der Patenterteilung oder Gebrauchsmustererteilung. Ohne unsere vorherige, schriftliche Zustimmung darf diese Zeichnung weder vervielfältigt, noch Dritten zugänglich gemacht werden. Diese Zeichnung darf durch den Empfänger oder Dritte auch nicht in anderer Weise missbräuchlich verwendet werden. Zuwiderhandlungen verpflichten zu Schadenersatz und können strafrechtlich verfolgt werden. We reserve all rights in this drawing as a patent or registered design. This drawing may neither be copied nor opened to a third party without our written agreement. It may also not be used improperly by the recipient or a third party in other ways. Contractors are obliged to compensation and can be prosecuted.